

YOKE WELD-ON LIFTING POINT WARNING AND APPLICATION INSTRUCTIONS



8-057

WARNING

- Loads may disengage from link if proper welding, assembly, and lifting procedures are not used.
- A falling load may cause serious injury or death.
- Do not use with damaged slings or chain. For sling inspection criteria see ASME B30.9.
- Read and understand these instructions before welding on, or using the lifting point.

Important Safety Information - Read and Follow

- Use weld-on lifting point only with ferrous metal (steel) work piece.
- After determining the loads on each weld-on lifting point, select the proper size using the Working Load Limit (WLL) ratings in Table 1.
- Always make sure the weld-on lifting point and mounting surface is free of dirt or contaminants before installation.
- Never use spacers between the weld-on lifting point and mounting surface.
- Always select proper load rated lifting device for use with weld-on lifting point.
- Attach lifting device ensuring free movement of weld-on lifting point bail (Figure 1).
- Apply partial load and check proper alignment. There should be no interference between load (work piece) and weld-on lifting point (Figure 2).
- Always ensure free movement of bail. The bail should pivot 180 degrees (Figure 4).
- The support structure that the lifting point is attached to must be of suitable size, composition and quality to support the anticipated loads of all operating positions. The required support structure thickness for a given application is dependent on variables such as unsupported length and material strength, and should be determined by a qualified individual.
- Never repair, alter, rework or reshape the lifting point bail by welding, heating, burning or bending.
- Only apply load in line with pivot direction except for lashing application.

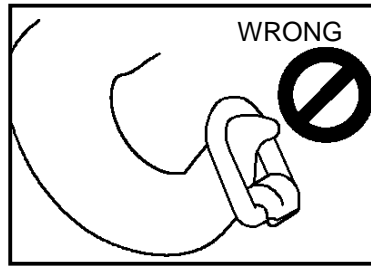

Figure 1

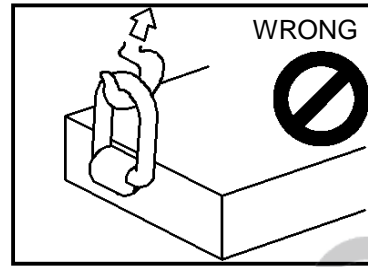
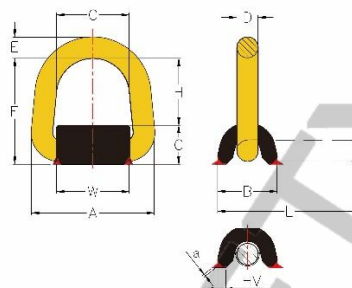

Figure 2

Table 1

8-057 Weld-on Lifting Point **



Item No.	Working Load Limit tonnes	Dimensions (mm)											N.W.	
		A	B	C	D	E	F	G	H	L	W	HV	a	kg
8-057-1T	1.0	83	37	48	14	14	75	26	49	105	48	5	3	0.5
8-057-3T	3.0	98	48	58	17	17	85	31	54	112	54	6	3	0.9
8-057-5T	5.0	120	56	66	22	22	92	37	55	154	56	7	3	1.3
8-057-8T	8.0	121	68	68	26	26	122	47	75	169	55	10	4	2.6
8-057-10T	10.0	146	68	82	20	30	125	47	78	191	70	10	4	2.8

* Design factor 5:1

Item No.	Working Load Limit tonnes	Dimensions (inch)											N.W.	
		A	B	C	D	E	F	G	H	L	W	HV	a	lbs
8-057-1T	1.0	3.27	1.46	1.89	0.55	0.55	2.95	1.02	1.93	4.13	1.89	0.2	0.12	1.1
8-057-3T	3.0	3.86	1.89	2.28	0.67	0.67	3.35	1.22	2.13	4.41	2.13	0.24	0.12	2.0
8-057-5T	5.0	4.72	2.20	2.60	0.87	0.87	3.62	1.46	2.17	6.06	2.20	0.25	0.12	2.9
8-057-8T	8.0	4.76	2.68	2.68	1.02	1.02	4.80	1.85	2.95	6.65	2.17	0.39	0.16	5.7
8-057-10T	10.0	5.75	2.68	3.23	0.79	1.18	4.92	1.85	3.07	7.52	2.76	0.39	0.16	6.2

* Design factor 5:1

** Designed to be used with ferrous work piece only.

Weld-on Lifting Point Welding Guidelines

- 1 Select the correct size weld-on lifting point to be used. Be sure to calculate the maximum load that will be applied to the weld-on lifting point.
- 2 Place the weld-on lifting point onto the mounting surface. The bottom of the link base must be parallel and even with the mounting surface.

- 3 Welding is to be performed by a qualified welder using a qualified procedure in accordance with American Welding Society and/or American Society of Mechanical Engineers requirements. Always follow your country or local mandatory regulations or codes.
- 4 The following welding recommendations should be included in the qualified procedure for welding to low or medium carbon plate steel. For welding to other grades of steel, a qualified weld procedure must be developed.
 - A. Weld material is to have a minimum tensile strength of 70,000 PSI (such as AWS A5.1 E-7018). Observe the electrode manufacturer's recommendations. Completely fill internal fillet created between weld-on lifting point base and mounting surface.
 - B. Before welding, all weld surfaces must be clean and free from rust, grease, paint, slag and any other contaminants.
 - C. Fillet weld leg size should be minimum shown in Table 1. Weld profiles to be in accordance with AWS. Weld size is measured by length of leg.
 - D. Welding should be carried out in a minimum of two passes to ensure adequate root penetration at the base of the lifting point.
 - E. Weld full length of "W" dimension on both sides of link base (Table 1).
 - F. Do not weld close to the bail. After welding, ensure bail pivots full 180° without interfering with the weld.
 - G. Do not rapidly cool the weld.
 - H. The ends of the weld must be ground sufficiently so that the weld-on lifting point will fit flush against the mounting surface.
 - I. A thorough inspection of the weld should be performed. No cracks, pitting, inclusions, notches or undercuts are allowed. If doubt exists, use a suitable NDE method, such as magnetic particle or liquid penetrant to verify.
 - J. If repair is required, grind out the defect and re-weld using the original qualified procedure.

Operating Safety

- Never exceed the capacity (WLL) of the weld-on lifting point (Table 1).
- Never apply load except in line with the pivot direction (Figure 4).
- When using lifting slings of two or more legs, make sure the forces in the legs

are calculated using the angle from the horizontal sling angle to the leg and select the proper size link.

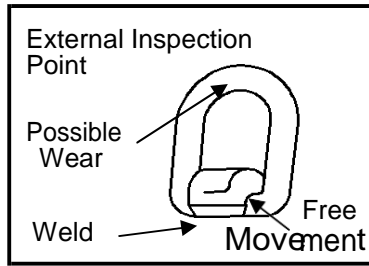

Figure 3

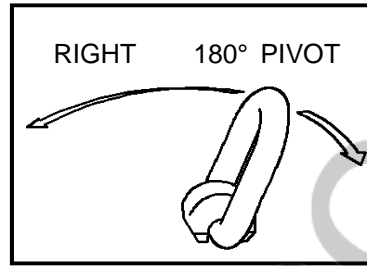
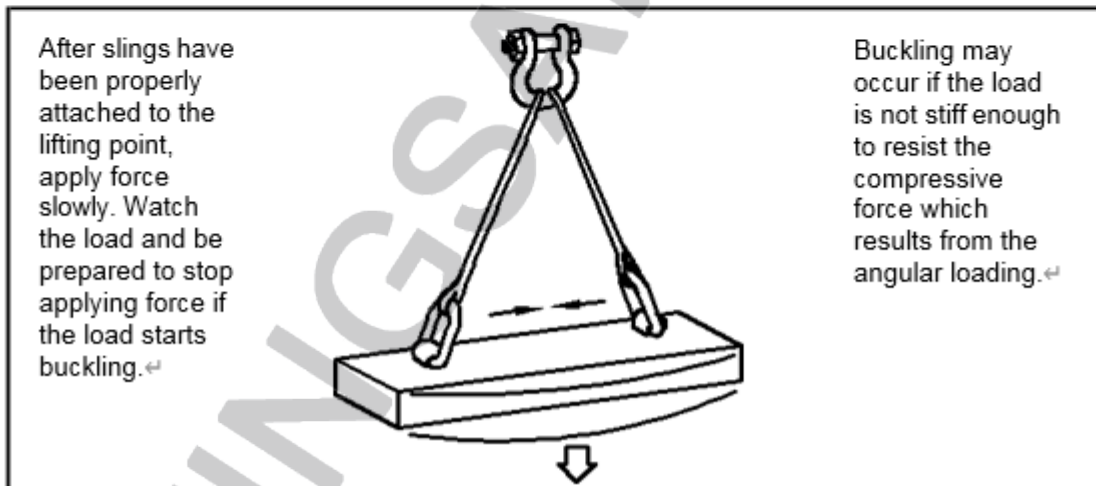
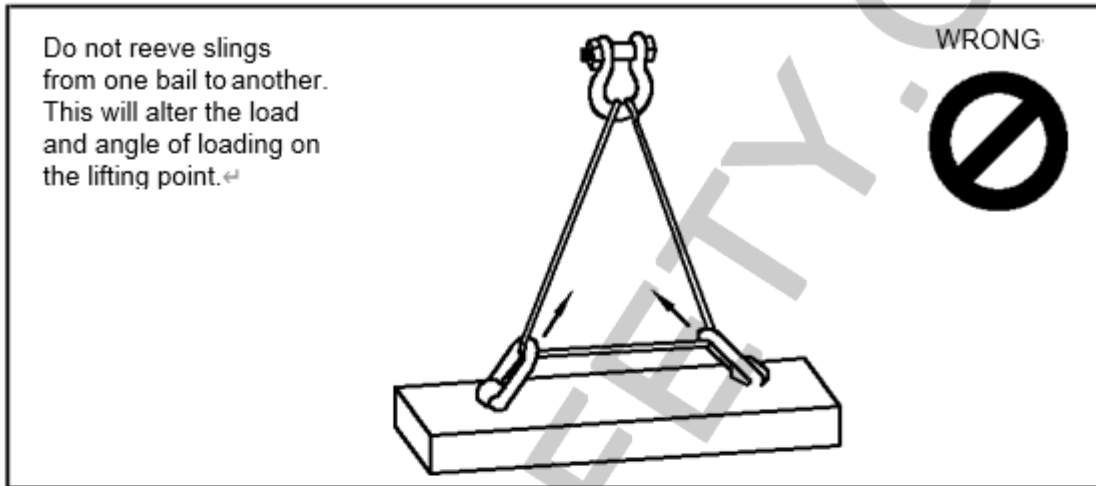

Figure 4



Weld-on Lifting Point Inspection / Maintenance

- Always inspect weld-on lifting point before use.
- Regularly inspect weld-on lifting point parts (Figure 3).
- Never use weld-on lifting point that shows signs of corrosion, wear or damage.
- Never use weld-on lifting point if bail is bent or elongated.
- Do not use part showing cracks, nicks or gouges.

- Always make sure there are no spacers used between weld-on lifting point and the mounting surface.
- Always be sure work piece surface is in total contact with the weld-on lifting point base mating surface.
- Always inspect the weld-on lifting point bail and base for wear.
- A visual periodic inspection of the weld should be performed. Check the weld visually, or use a suitable NDE method if required.

The welding should only be carried out by qualified welder according to Standards, e.g. EN 287 or AWS.

Support material

- Material of the welding block is S355J2+N (1.0577+N, St 52-3N, B.S. 4360.50D, AISI 1019 etc.).
- Prior to welding, the contact areas must be free from impurities, oil, paint, rust, scale, etc., for example by grinding. If the surface is at all corroded, all rust must be completely removed from the weld area. Painted surface must be prepared in the same way.
- The steel support member must have a carbon content of no less than 0.25% and no more than 0.40%.
- In ambient temperature of 10°C and below, pre-heating of the weld area prior to welding must be carried out.

Seam welding

- The welds must be sufficiently strong to take the required loads.
- The distance lugs assist in achieving the required root weld (approx. 3 mm).
- A minimum weld-seam width must be maintained to give adequate weld strength (see table)
- Start both, the root pass and final weld pass from the centre of the support to be welded.
- Before starting the final weld pass, clean well the root pass to avoid inclusions.
- The complete welding operation must be carried out continuously so that the parts do not have time to cool.
- Do not weld at the yellow powder coated tempered load ring.
- After welding, ensure bail pivots full 180° without interfering with the weld.
- Effects of temperature

The lifting points for weld on, types DAA, can together with the load (e.g. weld construction) be annealed, Temperature < 600° C, stress-release

without reduction of WLL.

The complete construction can be annealed stress release at $<600^{\circ}\text{C}$ without reduction of WLL.

Do not rapidly cool the weld.

- A thorough inspection of the weld should be performed. No cracks, pitting, inclusions, notches or undercuts are allowed. If doubt exists, use a suitable NDT method, such as magnetic particle or liquid penetrant to verify.
- If repair is required, grind out the defect and re-weld using the original qualified procedure.

Welding material

Weld material is to have a minimum tensile strength of 70,000 PSI (such as AWS A5.1 E-7018), following the electrode manufacturer's recommendations. Reference information as below:

MIG arc welding:

Wire diameter 0.8 - 1.2 as per DIN 8559-SG 3, AWS A

5.18. Important: do not weld in the open air during bad

weather Manual electric:

Direct current supply welding:

Electrodes according to EN ISO 2560-A - E 42 6 B 3 2, AWS A 5.5 : E

8018-G. Electrode: root pass and final weld pass, type E5154 B10 as per

DIN 1913, used in accordance with the manufacturers.

Alternating current supply welding:

Electrode as per DIN 1913, modified for alternating current

use. HV welding and final weld pass, type E5155 B10.

Specifications:

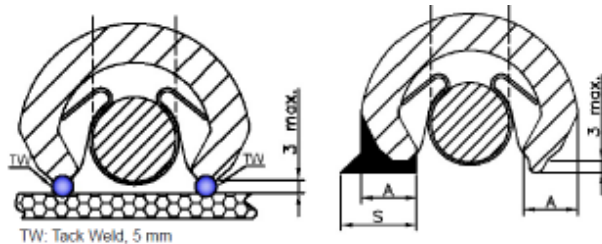

Art. No.	Code	WLL (ton)	Thickness A (mm)	Weld Size S (mm)
8-057-1T	DAA1	1.0	10	S=A+3
8-057-3T	DAA3	3.0	12	S=A+4
8-057-5T	DAA5	5.0	17	S=A+5
8-057-8T	DAA8	8.0	16	S=A+4
8-057-10T	DAA10	10.0	17	S=A+5



CERTIFICATE OF COMPLIANCE

Certificate No. MDC 1664

SGS Reference: **CST232151/1 (Previously CST150757/1)**

Date of Issue: **21st November 2016** Issue No.: **1** Expiry Date: **20th November 2021**

Client/Applicant: **YOKE Industrial Corp.
No. 39, 33rd Road, Taichung Industrial Park, Hsitung Dist., Taichung City 40768, Taiwan**

Manufacturer: **As above**

Scope of certification: **Full technical file assessment according to Annex VII 2006/42/EC**

Description of Equipment: **Weld-on Lifting Point**

Type/Series: **8-057-15T**

Serial Number(s): **8-057-1T, 8-057-3T, 8-057-5T, 8-057-8T, 8-057-10T, 8-057-15T**

Trade Mark/Name: **YOKE**

Assessment Performed: **Assessed for compliance with the requirements of Annex VII of the Machinery Directive 2006/42/EC**

Conclusion: **In the opinion of SGS United Kingdom Limited the submitted technical file referenced as CST232151/1 (Previously assessed under CST150757) satisfies the requirements of the Machinery Directive 2006/42/EC**

Autorised Signature
Anthony Garrett
Machinery Test Engineer

Page 1 of 1

The CE mark as shown below can be used, under the responsibility of the manufacturer, after completion of an EC Declaration of Conformity and compliance with all relevant EC Directives.



This document is issued by the Company subject to its General Conditions of Service printed hereon, available on request or accessible at <http://www.sgs.com/en/terms-and-conditions> and for electronic format documents, subject to Terms and Conditions for Electronic Documents at <http://www.sgs.com/en/terms-and-conditions/terms-e-document.aspx>.

Attention is drawn to the limitation of liability, indemnification and jurisdiction issues defined therein. Any holder of this document is advised that information contained hereon reflects the Company's findings at the time of its intervention only and within the limits of Client's instructions, if any. The Company's sole responsibility is to its Client and this document does not exonerate parties to a transaction from exercising all their rights and obligations under the transaction documents. This document cannot be reproduced except in full, without prior written approval of the Company. Any unauthorized alteration, forgery or falsification of the content or appearance of this document is unlawful and offenders may be prosecuted to the fullest extent of the law.

SGS United Kingdom Limited
Unit 12A & 12b, Bowburn South Ind Est, Bowburn Durham, DH6 5AD Tel +44 (0)191 377 2000 Fax +44 (0)191 377 2020
Registered in England No. 1193885 Rosemore Business Park, Ellesmere Port, Cheshire CH65 3EN www.sgs.com
Member of SGS Group (SGS SA)

This document is issued, on the Client's behalf, by the Company under its General Conditions of Service printed hereon.
The Client's attention is drawn to the limitation of liability, indemnification and jurisdiction issues defined therein.

Any other holder of this document is advised that information contained hereon reflects the Company's findings at the time of its intervention only and within the limits of Client's instructions, if any. The Company's sole responsibility is to its Client and this document does not exonerate parties to a transaction from exercising all their rights and obligations under the transaction documents.

MD 38 Iss 03 - 02/09/2016

SGSPAPER
17071561

